

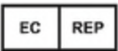

# Instruction Manual



Manufactured by SurgiBox Inc.  
1035 Cambridge Street  
02141 Cambridge,  
MA, United States  
Tel: 001 617 394 8903  
[www.surgibox.com](http://www.surgibox.com)



Authorized Representative in EU  
Veranex Germany GmbH  
Landsberger Strasse 302  
80687 Munich  
Germany



This document and the information contained within it are proprietary and confidential information of SurgiBox ("SurgiBox") and may not be reproduced, copied in whole or in part, adapted, modified, disclosed to others, or disseminated without the prior written permission of SurgiBox. This document is intended for use either by customers, and is licensed to them as part of their SurgiBox equipment purchase, or to meet regulatory commitments (and any amendments to it) and other local regulatory requirements. Use of this document by unauthorized persons is strictly prohibited.

SurgiBox provides this document without warranty of any kind, implied or expressed, including, but not limited to, the implied warranties of merchantability and fitness for a particular purpose.

SurgiBox has taken care to ensure the accuracy of this document. Unauthorized copying of this document, in addition to infringing copyright, might reduce the ability of SurgiBox to provide accurate and current information to users.



## About this Instructions For Use

Congratulations on your choice of the SurgiField™. This revolutionary system is designed to provide a surgical environment on demand any time, any place. Please study these Instructions For Use carefully to familiarize yourself with the specialized setup, operation, and safety protocols of your system prior to use. Keep this document in a secure, accessible location for future reference.

## General Product Information

- SB-T1-01 with the trade name SurgiBubble is a sterile, surgical enclosure. It is inflatable and single use. system made of clear film that is intended to be used on intact skin only. The SurgiBubble has multiple arm ports for the surgical team, line ports, and materials access ports to facilitate surgical intervention. By isolating the surgical site with a physical barrier, the SurgiBubble also protects the surgical site from physical debris and minimizes the exposure of the healthcare provider to patient body fluids.
- The Smart Control Module: SCM-T1-01 is medical device, a battery powered automated HEPA filtered airflow unit. It is used to inflate the SurgiBubble. The batteries used are referred as BP-04002M.
- The Popup frame: a non-medical accessory, PuF-T1-01 brings structural stability to the system.

## Intended Use

The SurgiBubble used with its accessories is intended to create a sterile barrier during surgical procedures and to isolate the surgical site from other areas of the patient's body and from non-sterile areas of the environment.

## Indications and Contra-Indications for Use

Maximum Limb Diameter for limb procedures: 33cm. Note: Maximum limb diameter applies to the limb and any attached or associated components. Users shall ensure that the largest cross-sectional dimension of the limb, including any attached devices (e.g., external fixators, dressings, or accessories), does not exceed the specified maximum diameter.

- Minimum Patient Body width for chest procedures: 20 cm
- Use on intact skin only
- Limit Patient contact to 24 hours























## Intended Users

Intended users for the SurgiField are surgeons who have been trained to perform surgical procedures on torso and/or limb areas of a patient.

## Environment for Use

This equipment is not intended for use in residential environments and may not provide adequate protection to radio reception in such environments. Use in a well-lit environment

## Symbol Glossary

 <p>Manufacturer</p>	 <p>Authorized representative in the european commission</p>	 <p>Waste electrical and electronic equipment</p>
 <p>Temperature Limit</p>	 <p>Consult instructions for use</p>	 <p>Do not use package if damaged</p>
 <p>Protect from heat and radioactive sources</p>	 <p>Keep dry</p>	 <p>Caution</p>
 <p>Batch Code</p>	 <p>Serial Number</p>	 <p>DC Voltage</p>
 <p>Sterilized using ethylene oxide</p>	 <p>Date of Manufacture</p>	 <p>Do not resterilize</p>
 <p>Do not reuse</p>	 <p>Type of Apply part: Type B</p>	 <p>Humidity Range</p>
 <p>Single sterile barrier system with protective packaging outside</p>	 <p>Distributor</p>	 <p>Unique Device Identifier</p>
 <p>Medical Device</p>	 <p>Treatment that is prescription-only</p>	<p><b>IP X1</b> Protection against dripping water (vertically falling drops) shall have no harmful effect.</p>



## General Warnings

Warnings highlight information vital to the safety of you, the operator, and the patient.

- IMPROPER SELECTION OR IMPROPER USE OF THE PRODUCT OR RELATED PARTS CAN CAUSE PERSONAL INJURY, TEMPORARY OR PERMANENT HEALTH IMPAIRMENT / DAMAGE AND/OR DEATH.
- Do not use if the package is damaged or unintentionally opened before use
- Do not handle the any element of the SurgiField without sanitizing your hands to avoid contamination.
- Use the SB on INTACT SKIN only. Do not use on burnt skin.
- Charge the batteries fully before starting any procedure: Do not use the product if the battery is not charged. Note: The battery is fully charged when 5 bars appear on the LCD and when the green light is on on the charger.
- To reduce contamination, do not reuse SB, it is intended to be used once
- Do not re-sterilize the SurgiBubble to avoid cross contamination.
- Do not operate the device if any of the parts are missing or damaged
- Do not connect and element of the SurgiField Kit with other medical devices to avoid possible damage
- Do not unplug battery pack when power is still turned on, to avoid electrocution
- Do not suddenly disengage SB from SCM when it is still turned on, to avoid contamination.
- ONLY use the Smart Control Module with SurgiBox provided battery (BP 04002M). Do not attempt to use any other battery, which might break the SCM.
- Clean the patient's surgical site before attaching the Surgibubble (SB) to avoid contaminatin.
- Do not keep SurgiBubble attached to the patient longer than 24 hours
- Gently clean the SCM before use. Wipe clean after each use or after extended storage to avoid unwanted contamination
- Gently clean the SB tube connection, SB tube connection ring and all caps to avoid potential contamination
- Do not use after expiry date
- Do not disassemble, puncture, or incinerate batteries, to avoid explosion of batteries.
- Do not insert a limb with attached components that exceed the maximum limb diameter.
- Be careful not to short the battery terminals because this could result in a fire hazard.

## Warnings During Usage

- Always sanitize your hands before entering the surgical site
- Always use a new pair of gloves after exiting the surgical site
- Always sterilize lines before inserting them in the surgical site
- Always sterilize tools before inserting them in the surgical site. Non sterile tools shall never enter the surgical site
- Always sanitize hands before and after entering tool in the environment
- Beware of sharp objects inside the surgical site



## Warnings After Usage

- Ensure that all fluids present in the surgical site are sucked out.
- Beware of sharp objects
- Ensure that you remove ALL tools and lines before peeling out the SB.
- The SurgiBubble is biological hazard waste, dispose in the appropriate container according to waste management guidelines.
- Do not resterilize.

## Cautions

Cautions highlight ways that you could damage the product and consequently void your warranty or service contract or ways that you could lose patient or system data.

- Operation temperature should be kept within 0-40°C to avoid damaging the device.
- Do not drop or shock the SCM to avoid potential malfunction.
- Do not poke fan while SCM is turned on to avoid injury.
- Do not tamper with HEPA filter at any stage.
- Do not modify the SCM in any way to avoid potential damage.
- Do not operate the SCM where it may be exposed to flammable gas.
- Do not use or store the SCM under a humid condition.
- Do not expose the device or its components under extreme temperatures or humidity. The device should not be exposed to direct sunlight for extended period of time.
- Use only the original components provided within the package.
- Do not conceal the SCM with a blanket, towel, or any other types of cover during usage.
- Do not disassemble or attempt to repair SCM or adaptor.
- Use only the original adaptor when charging the battery pack.
- Fully insert AC Adaptor (with USB Type C connector) into battery pack and power plug into the outlet before charging.
- When handling the AC Adaptor, take care not to do the following:
  - Do not damage.
  - Do not break, forcibly bend, pull, twist or pinch.
  - Do not tamper with it.
  - Do not bundle during use.
  - Do not place under heavy objects.
  - Do not use extension cords. Plug adaptor power cord directly into the outlet to avoid potential damage.
- Do not charge battery pack when it is in SCM. Remove battery pack from SCM prior charging.
- When disconnecting the power plug from the outlet, do not pull the power cord. Be sure to pull from the power plug safely.
- Always remove the adaptor from the SCM before cleaning.
- Remove battery pack from SCM if it will not be used for more than a week.
- Ensure all caps are firmly sealed after usage and before storage.
- Do not wash the device.
- Do not use a microwave or oven to boil or dry parts.
- Do not use a hair dryer to dry any components.



- Store the device and the components in a clean, dry and safe location.
- Do not use the SCM for any purpose other than inflating SB.
- Never clean with benzene or thinner.
- MRI unsafe, do not use in an MRI environment.
- Do not use the SCM close to strong electrical or electromagnetic fields. This may result in erroneous operation and create a potentially unsafe condition.
- Do not attempt to service/maintain the SCM during use.
- If abnormal behavior is observed due to EM disturbances, please relocate the SCM accordingly.
- This device should not be used adjacent to or stacked with other equipment.
- Please do not use any other cables or accessories not approved by the manufacturer in this manual to avoid negative influence on electromagnetic compatibility.
- The portable RF communication equipment can affect medical electrical equipment. We recommend a safety distance no closer than 30 cm (12 inches) to any part of the ME (Medical Electrical) equipment.
- Precautions shall be taken if the use location is close to (e.g. less than 1,5 km from) AM, FM or TV broadcast antennas.

## **Storage/ Shelf Life/Disposal SurgiBubble**

- Store the SurgiBubble between 10-23°C in a dry place away from sunlight. For shelf-life information, refer to the expiration date on the package. Dispose of the enclosure and its packaging per facility policy. If the sterile packaging is damaged or unintentionally opened, discard the product and do not use.
- After usage, the SurgiBubble is considered as hazardous waste, treat it according to local safe disposal practices.

## **Storage/ Shelf Life/Disposal SCM and PuF**

- Store in a dry place, in room temperature away from sunlight. End of life of SCM is 2 years, please see in the maintenance section for maintenance.
- Disposal shall be according to local safe environmental practices; this is waste of electrical equipment.

## **Storage/ Shelf Life/Disposal Batteries**

- Store in a dry place, in room temperature away from sunlight. End of life of devices is 2 years, please see in the maintenance section for maintenance.
- Batteries should be discarded if there are visual signs of damage. Batteries should be discarded in an environmentally safe manner. Properly dispose of batteries according to local regulations.

## Declaration-electromagnetic emissions

<p>The <u>SCM-T1-01</u> is intended for use in the electromagnetic environment (for professional healthcare) specified below.</p> <p>The customer or the user of the <u>SCM-T1-01</u> should assure that it is used in such an environment.</p>		
Emission test	Compliance	Electromagnetic environment-guidance (for professional healthcare environment)
RF emissions CISPR 11	Group 1	The <u>SCM-T1-01</u> uses RF energy only for its internal function. Therefore, its RF emissions are very low and are not likely to cause any interference in nearby electronic equipment.
RF emissions CISPR 11	Class A	The <u>SCM-T1-01</u> is suitable for use in all establishments other than domestic and those directly connected to the public low-voltage power supply network that supplies buildings used for domestic purposes.
Harmonic emissions IEC 61000-3-2	Class A	
Voltage fluctuations /flicker emissions IEC 61000-3-3	Compliance	



## Declaration-electromagnetic immunity

The SCM-T1-01 is intended for use in the electromagnetic environment (for professional healthcare) specified below. The customer or the user of the SCM-T1-01 should assure that it is used in such an environment.

Immunity test	IEC 60601 test level	Compliance level	Electromagnetic environment-guidance (for professional healthcare environment)
Electrostatic discharge (ESD) IEC 61000-4-2	Contact:±8 kV Air±2 kV,±4 kV,±8 kV,±15 kV	Contact:±8 kV Air±2 kV,±4 kV,±8kV, ±15 kV	Floors should be wood, concrete or ceramic tile. If floors are covered with synthetic material, the relative humidity should be at least 30%
Electrical fast transient/burst IEC 61000-4-4	± 2kV for power supply lines ± 1kV for input/output lines	± 2kV for power supply lines Not applicable	Mains power quality should be that of a typical professional healthcare environment.
Surge IEC 61000-4-5	± 0.5kV, ±1kV line(s) to line(s) ± 0.5kV, ±1kV,± 2kV line(s) to earth	± 0.5kV, ±1kV line(s) to line(s) Not applicable	Mains power quality should be that of a typical professional healthcare environment.
Voltage Dips, short interruptions and voltage variations on power supply input lines IEC 61000-4-11	Voltage dips: 0 % UT; 0,5 cycle 0 % UT; 1 cycle  70 % UT; 25/30 cycles  Voltage interruptions: 0 % UT; 250/300 cycle	Voltage dips: 0 % UT; 0,5 cycle 0 % UT; 1 cycle 70 % UT; 25/30 cycles  Voltage interruptions: 0 % UT; 250/300 cycle	Mains power quality should be that of a typical professional healthcare environment. If the user of the <u>SCM-T1-01</u> requires continued operation during power mains interruptions, it is recommended that the <u>SCM-T1-01</u> be powered from an uninterruptible power supply or a battery.
Power frequency (50, 60 Hz) magnetic field IEC 61000-4-8	30 A/m 50 Hz or 60 Hz	30 A/m 50 Hz and 60 Hz	The <u>SCM-T1-01</u> power frequency magnetic fields should be at levels characteristic of a typical location in a typical professional healthcare environment.

NOTE UT is the a.c. mains voltage prior to application of the test level.



## Declaration-RF Devices

Recommended separation distance between portable and mobile RF communications equipment and the SCM-T1-01

The SCM-T1-01 is intended for use in an electromagnetic environment (for professional healthcare) in which radiated RF disturbances are controlled. The customer or the user of the SCM-T1-01 can help prevent electromagnetic interference by maintaining a minimum distance between portable and mobile RF communications equipment (transmitters) and the SCM-T1-01 as recommended below, according to the maximum output power of the communications

Rated maximum output power of transmitter W	Separation distance according to frequency of transmitter m		
	150 kHz to 80 MHz	80 MHz to 800 MHz d =1,2	800 MHz to 2,7 GHz d =2,3
1	12	12	23
1	38	38	73
1	12	12	23
10	38	38	73
100	12	12	23

For transmitters rated at a maximum output power not listed above, the recommended separation distance  $d$  in meters (m) can be estimated using the equation applicable to the frequency of the transmitter, where  $p$  is the maximum output power rating of the transmitter in watts (W) according to the transmitter manufacturer.

NOTE1 At 80 MHz and 800 MHz, the separation distance for the higher frequency range applies.



# Package Contents

## Check before use

The following items are contained within the package. Please check all parts for visible damage. Replace any damaged parts before use. In case of missing components, malfunction or damage, please contact [sales@surgibox.com](mailto:sales@surgibox.com)

## Contents of the Box: SCM-T1-02



### 1 Smart Control Module

The Smart Control Module should have a the battery cap and a tube connection ring and a velcrow strap in the battery housing.



### 1 Instruction for Use Sheet



### 2 Battery Packs



### 1 Smart Charger

Could be EU or US type, depending on your order

## Contents of the Box: PuF-T1-01

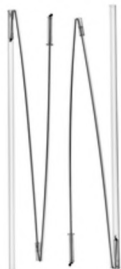

### 2 Sets of Pop-Up Frames

Each set has one left and one right frame

## Contents of the Box: SB-T1-02



### 6 SurgiBubbles

# Instructions for Use Torso Procedures

1 Shave and clean the surgical site.

2 With the help of an assistant, assemble the Pop-up Frame (PuF) by snapping together the two halves then connecting them to form an oval.

3 Open package by peeling from corner tab. One corner is easier to peel than others.

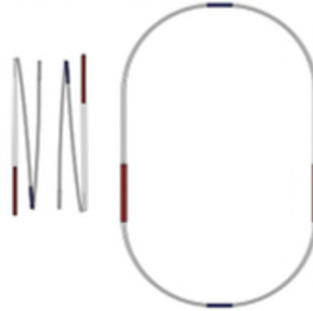

4 Orient the SurgiBubble (SB) and open over the patient. Remove the adhesive backing as opening. Firmly smooth adhesive around the surgical site so that there are no wrinkles/folds.

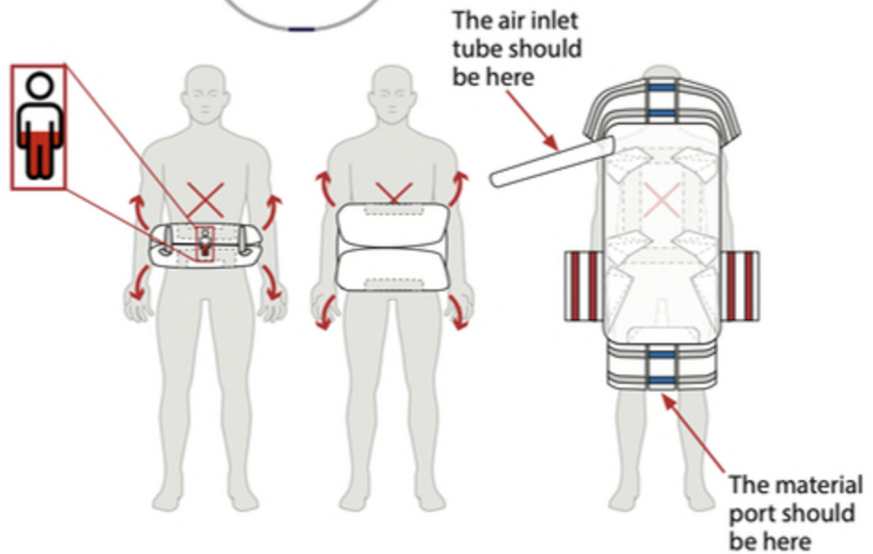

5 Place the Smart Control Module (SCM) inflation component alongside the SB at the head end. Do not attach the SCM yet. The set up should be 30"/75cm wide so the SCM is far enough from the SB that no kinking occurs.

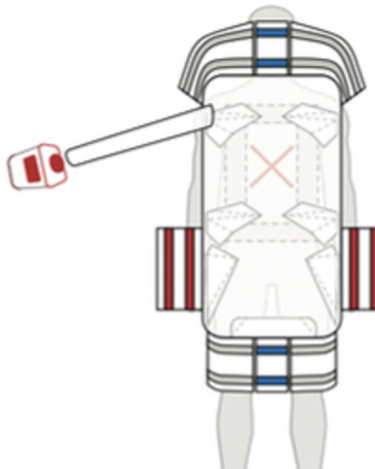

6 With the help of the white velcro strap insert and connect the battery, aligning the battery plug-in port with the arrow.

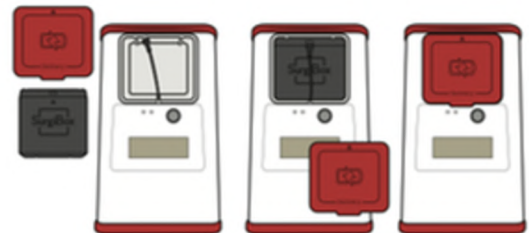

7 Attach the PuF to the SB following the colored labels on the PuF: RED, then BLUE.

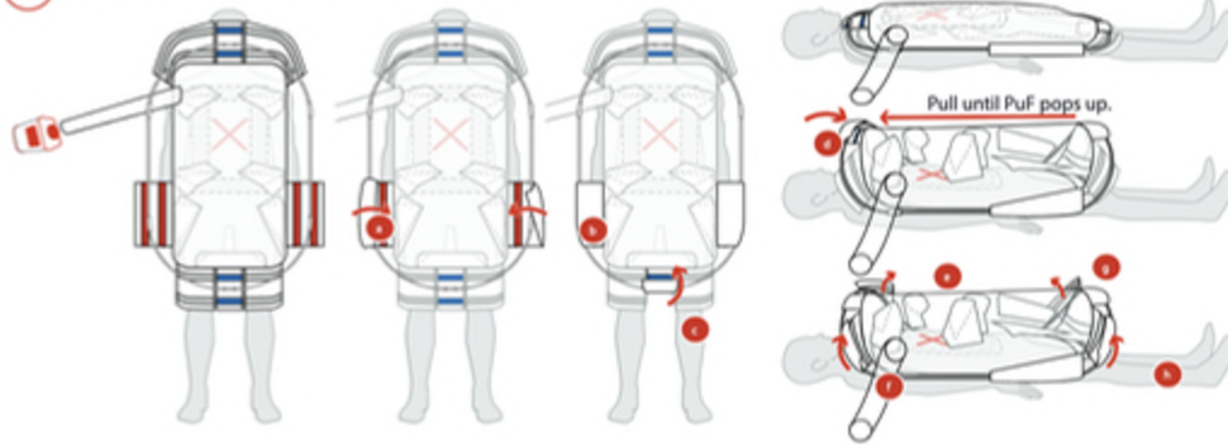

8 Open the nozzle caps, remove the connection ring from the nozzle, and attach the SB tube to the SCM as shown below.

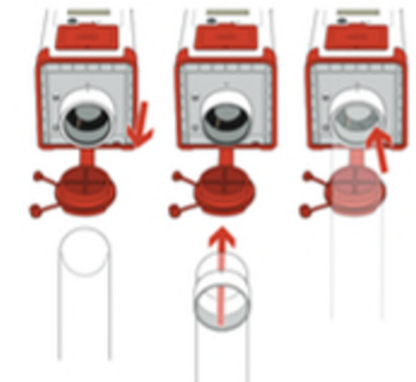

9 Connect the pressure tube to the lower port on the SCM. Test the connection of pressure tube and ring/nozzle by gently pulling on to them.

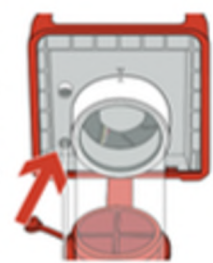

10 Remove filter cap on the back of the SCM.



11 Power on the SCM to inflate the SB, wait until the SB has fully inflated.

12 Insert the surgical tray through the magnetic ports and ensure that the port is correctly sealed (no leaks) after closing it.



13 Be sure to be gloved BEFORE entering the SB. Unfold only the sleeves that will be used. Place thumbs through the thumb hooks in the sleeves, then double glove once inside the SB.

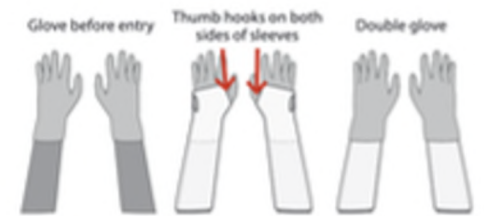

14 Remove the perforated panel of the SB to gain access to the surgical site.

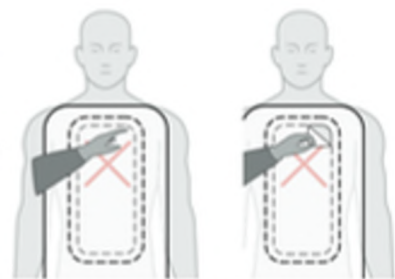

Gently press a desired corner then peel back.

15 After finishing all sutures, remove all tools, and suction excess fluids, then remove the SB.

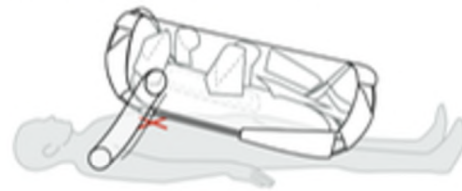

16 Clean the SCM and PuF using bleach wipes after use.



# Instructions for Use Limb Procedures

1 Shave and clean the surgical site.

2 With the help of an assistant, assemble the Pop-up Frame (PuF) by snapping together the two halves then connecting them to form an oval.

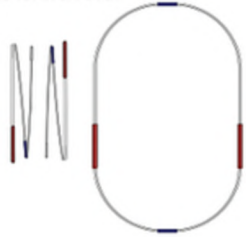

3 Open package by peeling from corner tab. One corner is easier to peel than others.



4 Orient the SurgiBubble (SB) and open beside the patient.

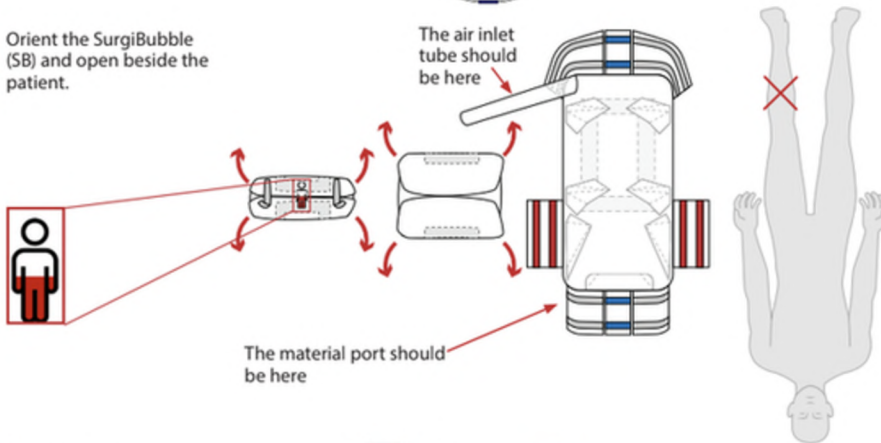

5 Place the Smart Control Module (SCM) inflation component alongside the SB at the head end. Do not attach the SCM yet.

The set up should be 30"/75cm wide so the SCM is far enough from the SB that no kinking occurs.

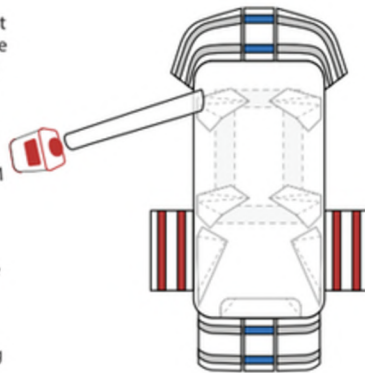

6 With the help of the white velcro strap insert and connect the battery, aligning the battery plug-in port with the arrow.

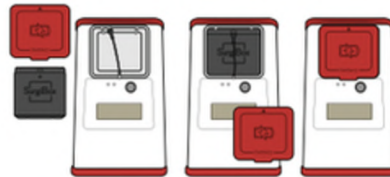

7 Attach the PuF to the SB following the colored labels on the PuF: RED then BLUE.

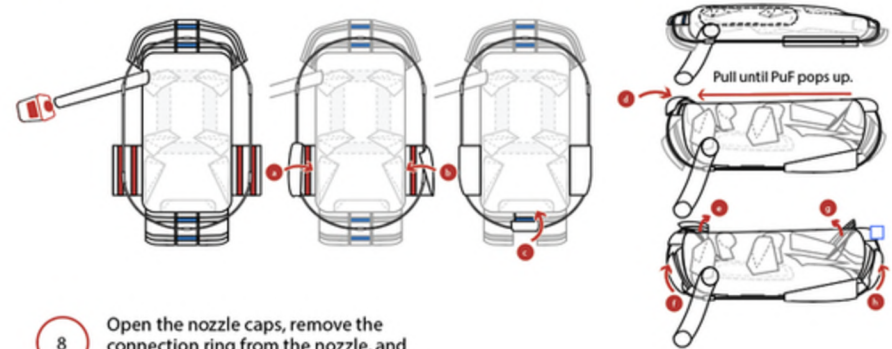

8 Open the nozzle caps, remove the connection ring from the nozzle, and attach the SB tube to the SCM as shown below.

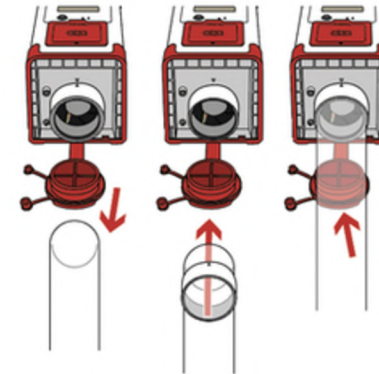

9 Insert the surgical tray through the magnetic ports and ensure that the port is correctly sealed (no leaks) after closing it.

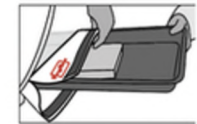

10 Connect the pressure tube to the lower port on the SCM. Test the connection of pressure tube and ring/nozzle by gently pulling on to them.



11 Remove Filter cap on the back of the SCM.

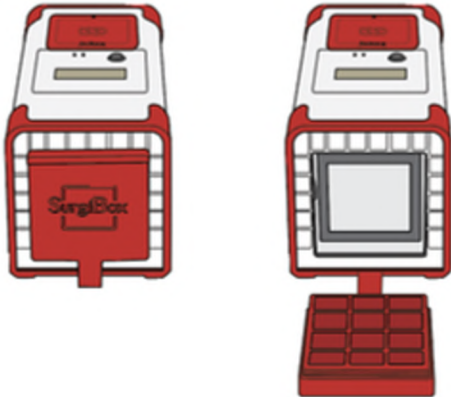

12 Power on the SCM to inflate the SB, wait until the SB has fully inflated.

13 Be sure to be gloved BEFORE entering the SB. Unfold only the sleeves that will be used. Place thumbs through the thumb hooks in the sleeves, then double glove once inside the SB.

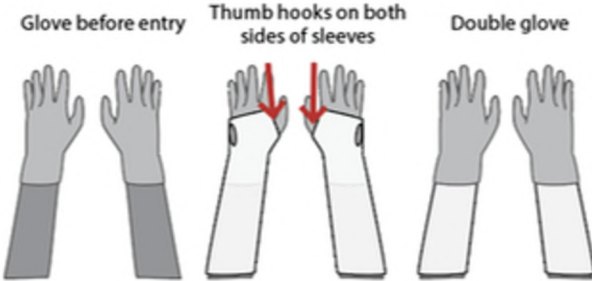

14 Trim the sleeve before insertion of the limb. Place SB onto the patient around the surgical site using the foot-end, orthopedic sleeve.

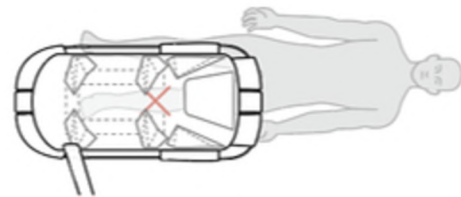

15 After finishing all sutures, remove all tools, and suction excess fluids, then remove the SB.

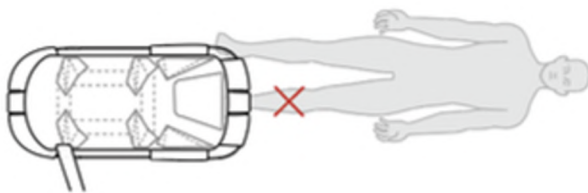

16 Clean the SCM and PuF using bleach wipes after use, do not clean the filters

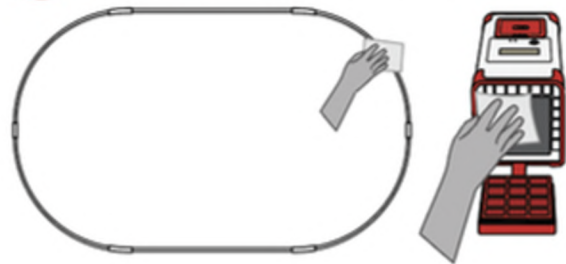



# Alarms and Alerts

## Event: Low Battery

- Trigger condition: Battery voltage is less than 12.8 V.
- Notification:
  - (a) LCD shows "Low Battery / Turn OFF and Change" continuously.
  - (b) Yellow LED remains on continuously.
- Type: Low priority alarm.
- Condition delay: SCM examines battery voltage every 5 seconds.

## Event: Tube not connected

- Trigger condition: SCM manages the pressure reading when it is lower than 9 Pa after the system has been powered on for  $\geq 2$  minutes.
- Notification: LCD shows "Switch OFF / Check Pressure Tube".
- Type: Information Signal.
- Condition delay: 125 +/- 3 seconds.

## Event: Low pressure issue

- Trigger condition: System detects that pressure is lower than 9 Pa.
- Notification: The bottom line of the LCD shows "PRESSURE ISSUE".
- Type: Information Signal.

## Troubleshooting Guide

**Trouble: HEPA becomes dirty or is damaged**

- Possible Cause: Extensive use.
- Corrective Action: Contact SurgiBox sales.

**Trouble: The green LED does not turn on and SCM is powering on**

- Possible Causes:
  - Power button is not pressed.
  - Disconnection between battery pack and connector cable.
  - Battery pack is low.
- Corrective Actions:
  - Press the power button.
  - Insert Type C connector cable into battery pack jack.
  - Replace with a fully charged battery pack.

**Trouble: The green and yellow LEDs are turned on; LCD shows "Low Battery / Turn Off and Change"**

- Possible Cause: Battery charge low.
- Corrective Action: Replace with a fully charged battery pack.

**Trouble: The green LED is on while LCD shows "Switch Off / Check Pressure Tube"**

- Possible Causes:
  - The SB tube is not properly connected to SCM.
  - The SB pressure tube is not properly connected to SCM.
  - The material port of SB with magnetic closure is opened.
  - An arm port of SB is open.
- Corrective Actions:
  - Reconnect the SB tube with SCM properly.
  - Reconnect the SB pressure tube with pressure connector properly.
  - Close the material port with magnetic closure of SB.
  - Fold the arm port of SB properly to prevent excessive air loss.

**Trouble: Buzzer notification is activated**

- Possible Cause: New updates on LCD.
- Corrective Action: Review text on LCD and check SCM function.

**Trouble: SCM cannot be turned on or is shut off**

- Possible Cause: Low power battery or flat battery.
- Corrective Action: Insert Type C connector into battery pack first prior to plugging into outlet.

**Trouble: Battery pack cannot be charged after extended period of unuse**

- Possible Cause: Battery pack has entered under voltage protection mode.
- Corrective Action: Insert Type C connector into battery pack first prior to plugging into outlet.

**Trouble: AC Adapter fails to initiate charging (red light is shown)**

- Possible Cause: AC Adapter failure.
- Corrective Action: Contact your local vendor.



## Maintenance

- SurgiBox recommends to purchase batteries after 500 cycles
- After 2 years of usage contact SurgiBox after-sales department to order new Pop-up frames

## Contact information

### Serious Incidents

Any serious incident shall be reported to SurgiBox at [qm@surgibox.com](mailto:qm@surgibox.com) and to the relevant competent local authority.

For EUROPE customers the competent authority is DE/CA304 - Marktüberwachung Medizinprodukte Bayern at [MP.BY@reg-opf.bayern.de](mailto:MP.BY@reg-opf.bayern.de)

### Feedback

We are always looking to improve and your feedback is invaluable to us. If you have any comments, suggestions, or need assistance, please don't hesitate to reach out to our sales team ([sales@surgibox.com](mailto:sales@surgibox.com)). We are here to ensure your complete satisfaction.

### General Contact and After Sales

Please reach out to us by email:  
[sales@surgibox.com](mailto:sales@surgibox.com)

or mail us:

SurgiBox Inc. c/o Geek Offices  
1035 Cambridge Street Unit 1  
02141 Cambridge, MA  
USA

## Warranty

This product is guaranteed by SurgiBox for a period of 2 years after the date of purchase. The proper construction, workmanship and materials of this product is guaranteed by SurgiBox. During the warranty, SurgiBox will repair or replace any defective parts or products.

- The guarantee covers only products purchased in Europe
- The guarantee does not cover any of the following:
  - Costs for repairs and / or defects resulting from repairs done by unauthorized persons.
  - Periodic check-ups and maintenance.
  - Failure or wear of accessories or other attachments other than the main SCM itself, unless explicitly guaranteed above.
  - Costs arising due to non-acceptance of a claim (those will be charged for).
  - Damages of any kind including personal caused accidentally or from misuse.

Should guarantee service be required please apply to the dealer whom the product was purchased from or an authorized SurgiBox distributor. For the address refer to the product packaging / literature or to your specialized retailer. If you have difficulties in finding SurgiBox customer services, visit our website (<https://www.surgibox.com/>) for contact information.

- Repair or replacement under the guarantee does not give rise to any extension or renewal of the guarantee period.
- The guarantee will be granted only if the complete product is returned together with the original invoice issued to the consumer by the retailer. SurgiBox reserves the right to refuse the guarantee service if any unclear information has been given.



# Specification Sheet

The SurgiField, comprised of the SurgiBubble used with the battery-powered Smart Control Module (SCM) and the Pop-Up frames is intended to create a sterile barrier during surgical procedures and to isolate the surgical site from other areas of the patient's body and from non-sterile areas of the environment.

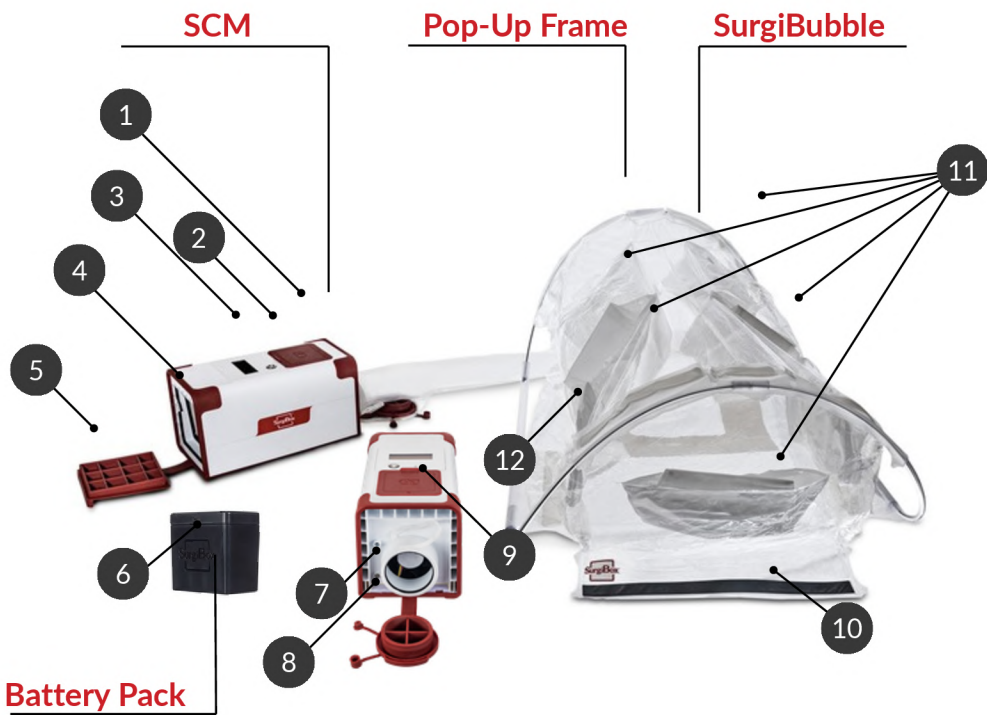

- 1. Filter Cap
- 2. On/Off Button
- 3. LCD Screen
- 4. Air Filter
- 5. Filter Cap
- 6. USB-C Battery Connector
- 7. Pressure Sensor
- 8. Pressure Tube Connector
- 9. LEDs
- 10. Material Port
- 11. Arm Ports
- 12. Fluid Collectors

# Smart Control Module

## SCM-T1-01

The Smart Control Module, SCM-T1-01 is a battery-powered HEPA filtered air generator that inflates the SurgiBubble and maintains the inflation at a specified air flow and specified controlled over pressure. It is powered by the SurgiBox Provided Battery Pack, BP-T1



### Physical Parameters

- Weight
  - 3.5kg±10%
- Size
  - Height: 167.7±2 mm
  - Width: (bottom part): 164±2 mm
  - Length without connector: 313.1 ± 2 mm
- Materials
  - Polycarbonate (PC) and Silicone

### Temperature and Humidity

- During Operation
  - 10 to 45°C
- Storage
  - -20 to 50°C, 45 to 65% RH (within 1 year)

### Alerts

- Low Battery:
  - Two levels: 80% battery depleted;
  - 95% battery depleted inflation in 90 seconds
- Unusual inflation or leak patterns

### Warranty

- 2 Years
- Lifetime of Device: 2 Years

### Fan Rating

- 175L inflation in < 120 seconds
- 132 CFM (3.7 m<sup>3</sup>/min), providing 20 air changes per hour in the SurgiBubble
- 5.4 in H<sub>2</sub>O
- 12V

### Power Consumption

- 45W - Maximum
- 10W - Typical

### Filtration

- PM 2.5 Pre-filter
- Metallic Mesh
- HEPA-13 Filter 99.97% particles @0.3µm

### Standard Compliance

- IEC 60601-1
- IEC 60601-1-2
- IEC 60601-1-8
- ASTM D4169 Transportation Safe
- IP X1

# SurgiBubble

## SB-T1-01

The SurgiBubble is a Class Is sterile, inflatable and single use surgical enclosure. The SurgiBubble has multiple arm ports for the surgical team, line ports, and materials access ports to facilitate surgical intervention. By isolating the surgical site with a physical barrier, the SurgiBubble also protects the surgical site from physical debris and minimizes the exposure of the healthcare provider to patient body fluids and droplet contamination from the surgical site. It is compatible with limb and torso procedures.



Inflated



Packaged

## Physical Design & Ergonomics

- Access Points
  - 7 individual sleeves, line ports for tubes, and a magnetic material port for surgical tool transfer.
- Patient Interface
  - Medical-grade adhesive to adhere to the patient.
- Fluid Management:
  - Integrated blood channels to collect fluids during surgery.

## Technical & Material Specifications

- Material
  - TPU (Thermoplastic Polyurethane) and synthetic non-woven textile.
- Weight:
  - 800 grams.
- Dimensions:
  - Flat/Packaged: 22.3 cm×50.5 cm×9.3 cm
  - Inflated: 121.49 cm×58.35 cm×41.15 cm
  - 173.5l inflated volume

## Standard Compliance

- Biocompatibility: ISO 10993-1:2025
- Risk Management: ISO 14971:2019 (+ A11:2021)
- Sterilization (EO): ISO 11135:2014 (+ A1:2018)
- Usability Engineering: IEC 62366-1:2015 (+ A1:2020)

## Sterilization & Packaging

- Sterilization Method
  - EO (Ethylene Oxide).
- Packaging Type
  - Tyvek Pouch.
- Shelf Life
  - 2 years.
- Transit Standard
  - ASTM D4169

# Pop-Up Frames

## PuF-T1

The Puf-T1 or Pop-Up frames are structural rods that provide shape and support to the SurgiBubble, keeping it upright and stable by connecting to its sleeves. The Pop-up Frames (Puf-T1) are collapsible, multi-section plastic poles essential for the structural integrity of the SurgiBubble. An internal elastic cord connects the hollow segments, allowing the poles to bend, snap back for quick assembly, and fold down for compact storage. These rods provide shape and support by connecting to the SurgiBubble's sleeves, ensuring it remains upright and stable.

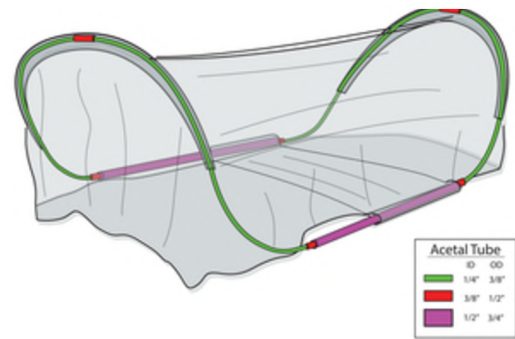
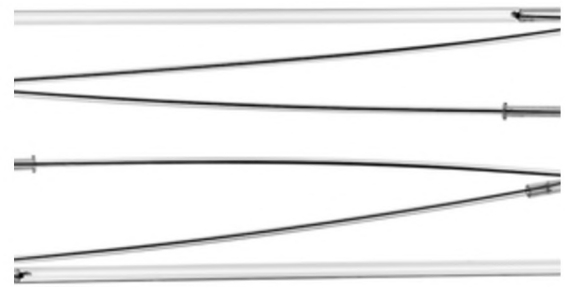

## Technical & Material Specifications

- Material
  - POM (Polyoxymethylene) and Bungee Cord
- Weight
  - 300g
- Size
  - 356.9cm (Total Length) / 73.6cm (Folded) / 1.9cm (Max Diameter)
- Safety Compliance
  - IEC 62366:2020 (Usability for Medical Devices)

## Battery Pack and Smart Charger

### BP-T1 and CC-T1

The BP-T1 (BP-04002M) is a compact, medical-grade Lithium-Ion battery featuring an integrated battery management system (BMS). It utilizes Ultra-low Voltage Protection (UVP) to extend its service life and maintains a stable voltage across varying temperatures without emitting gases. The battery is recharged via the included CC-T1 USB-C smart charger (EU for Europe and US for USA)



Battery Pack



Smart Charger

### BP-T1 Physical Characteristics

- Battery Chemistry
  - Lithium-Ion (Li-Ion)
- Dimensions
  - 90mm (L) x 50mm (W) x 80mm (H) [ $\pm 0.3$  mm]
- Weight
  - 500 g  $\pm 10\%$

### BP-T1 Charging Specifications

- Charging Method
  - CC-CV (Constant Current - Constant Voltage)
- Charging Voltage
  - 16.4 V
- Charging Current
  - <3000 mA
- Standard Charge Time
  - 270 minutes (at 2950 mA)
- Connector Type:
  - USB-C (Use only SurgiBox provided charger)
- Continuous Discharging Current
  - <4A

### CC-T1 Standard Compliance

- EN 62368-1 (Safety)
- EN 55032/55035 (EMC - Electromagnetic Compatibility)
- FCC (Federal Communications Commission)

### BP-T1 Electrical Performance

- Capacity
  - Rated: 6900 mAh (<100Wh)
  - Nominal: 6600 mAh
- Voltage
  - Nominal :14.4 V
  - Discharging End Voltage: 12.4 V
- Self-Discharge (Typical)
  - 2 mA / hour

### BP-T1 Environmental & Durability

- Operating Temp (Charging):
  - 10°C to +45°C
- Operating Temp (Discharge)
  - 0°C to 60°C
- Storage Conditions
  - -20°C to 50°C; 45% to 65% RH (up to 1 year)
- Cycle Life (Typical)
  - 500 Cycles at 75% capacity

### BP-T1 Standard Compliance

- Cell Certification
  - IEC 62133-2:2017
- Pack Certification
  - UL 62133-2:2017
- Transport Certification
  - UN 38.3 (Pack certification)